

GOING THE DISTANCE.

MERITOR MTA SUSPENSION SYSTEM

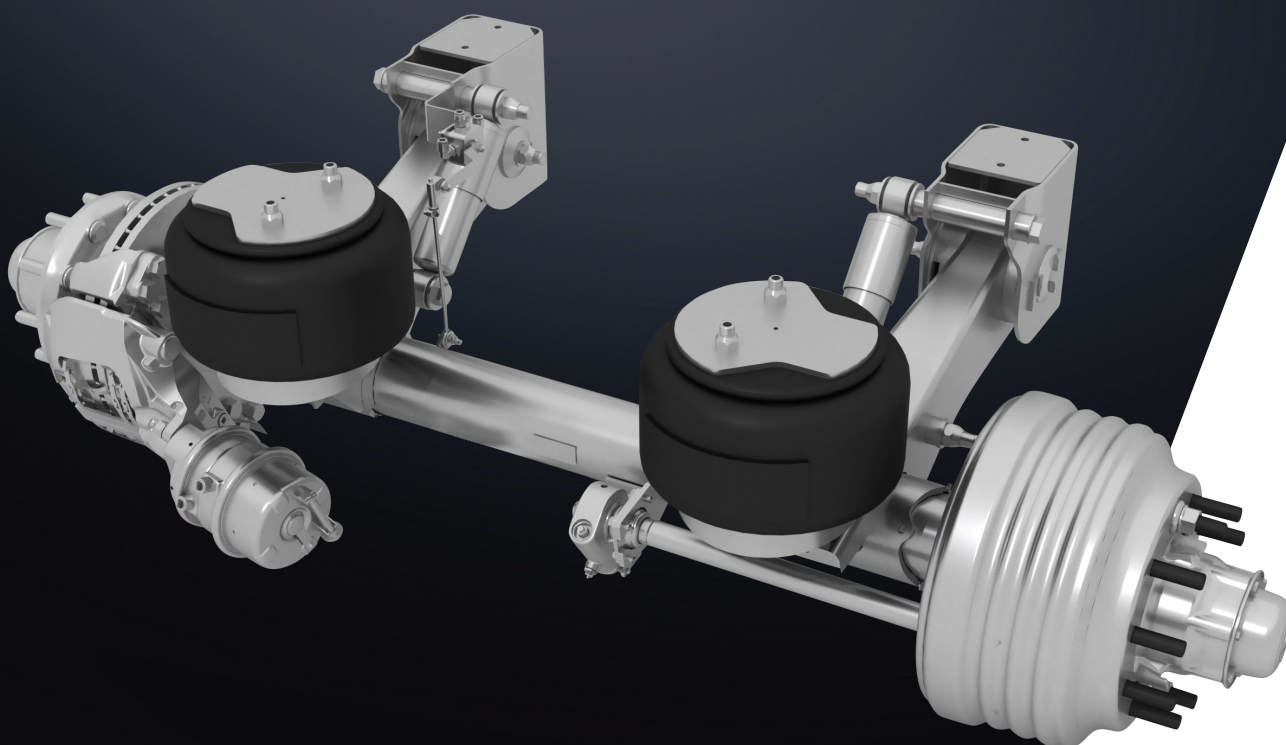

Meritor

**FOR
A WORLD
THAT'S
ALWAYS ON™**

GOING THE DISTANCE.

MTA SUSPENSION SYSTEM

The MTA trailer suspension system from Cummins-Meritor is proven to handle the demands of long-distance trucking. For over 10 years, thousands of MTA axles have covered millions of miles in North America, setting industry leading standards for reliability and durability.

Cummins-Meritor Australia expands its product offering to the Australian market with the introduction of the MTA25 trailer suspension package.

This integrated trailer axle and suspension package enables ease of installation, features trusted Meritor Q+ brakes with lightweight X30 drum or EX+ brakes all with the same ease of serviceability, reliability, and parts availability known for Meritor Drivetrain products.

Have confidence knowing the MTA25 is backed by our locally based customer service teams, and a network of over 300 parts outlets nationwide with a 48 hour emergency parts service to keep trailers on the road.

MTA AVAILABLE IN TOP AND LOW MOUNT

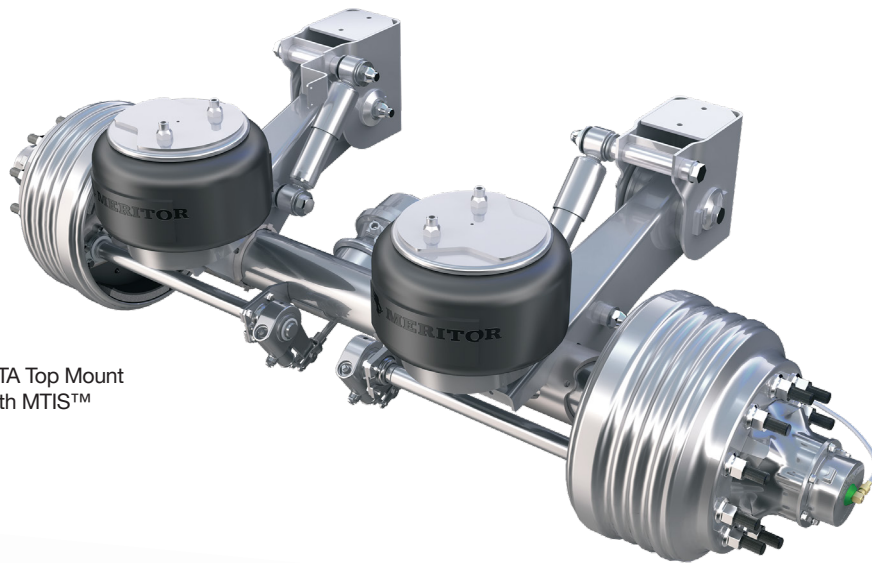

MTA Top Mount
with MTIS™

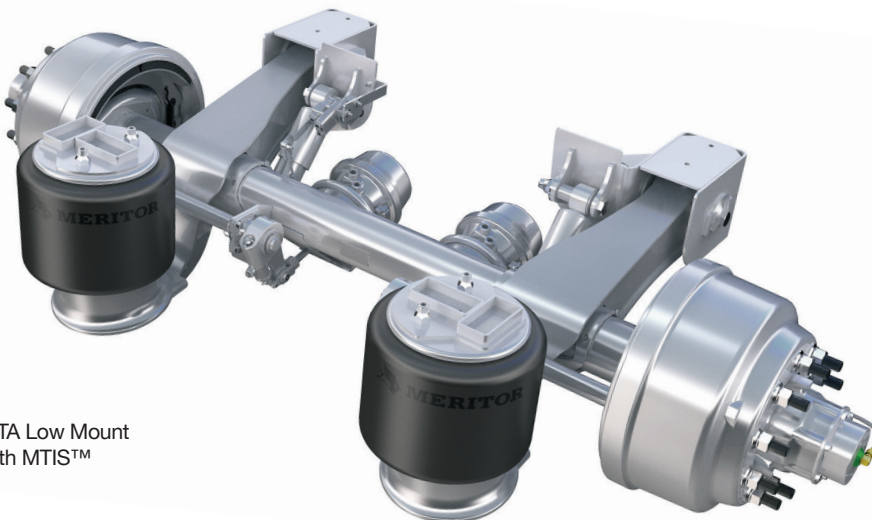

MTA Low Mount
with MTIS™

FEATURES & BENEFITS

The MTA trailer axle family is packed with a number of features designed to keep you and your fleet on the road and not in the workshop.

FEATURES

- Patented Axle Wrap Design
- Heavy Duty Shock Absorber
- Patented Pivot Bushing
- Lightweight Design
- Meritor Q+ and EX+ brakes
- Parts availability, technical support and warranty

BENEFITS

- Overall suspension durability, secure axle connection
- Superior damping force, braking performance and vehicle control
- Interleaf shim provides better fore/aft stiffness than competing designs, maintaining better axle alignment down the road and reduces tyre wear and roll induced steer allowing for larger payloads
- Fast and simple installation
- Industry leading drum and disc brake benefits, serviceability and reliability

MTA SUSPENSION SYSTEM

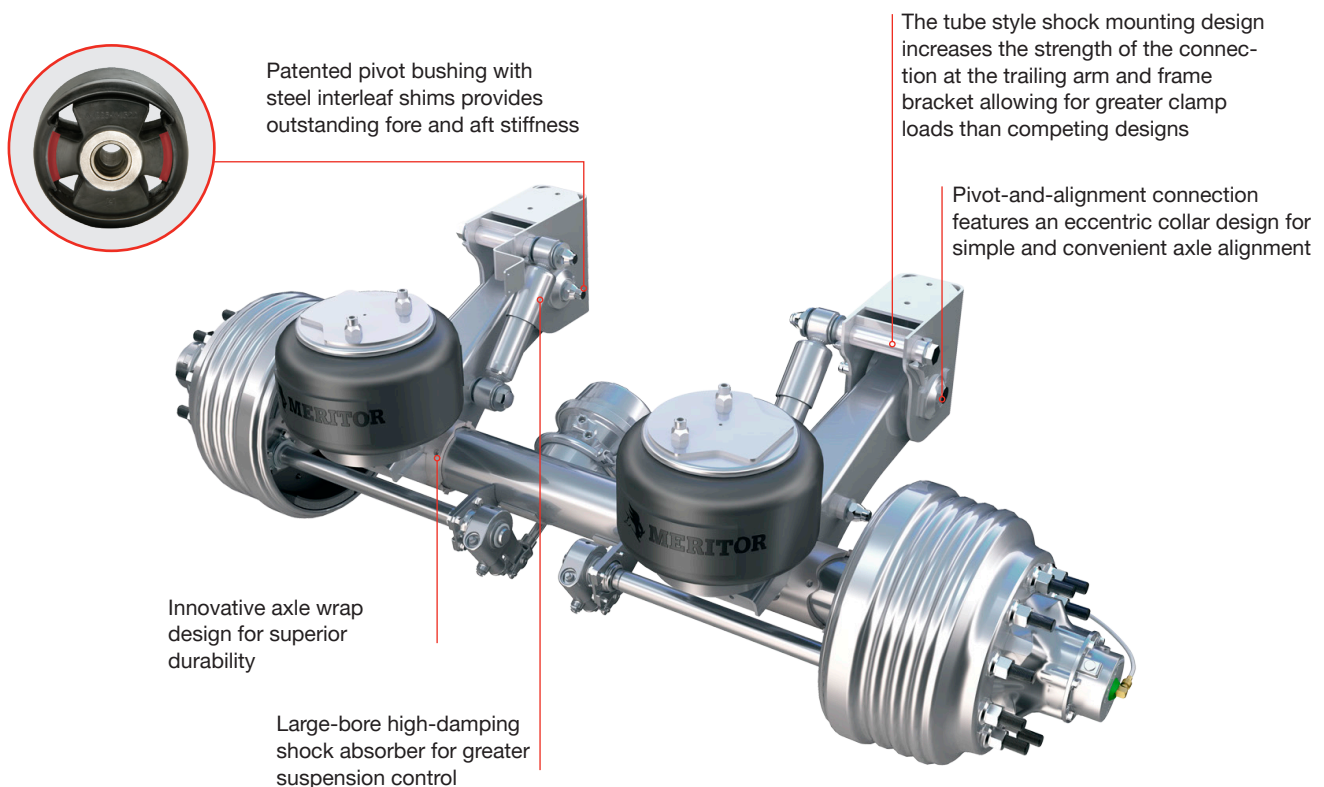

MTA Top Mount with MTIS™

OPTIONAL FEATURES

LIFT KIT

The MTA Lift Kit is a durable, reliable quick-response system that allows users to efficiently raise select axles, improving maneuverability and extending tire life. Available in painted or galvanized finishes, the lift kit attaches easily and can be installed by the OEM or as a field retrofit on the MTA Top Mount and MTA Low Mount.

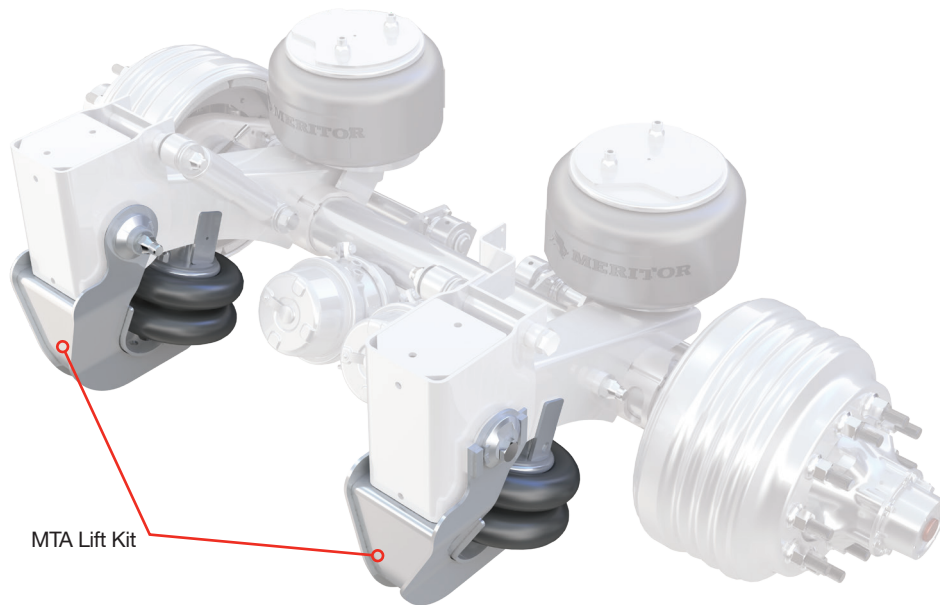

MERITOR TYRE INFLATION SYSTEM (MTIS)

MTIS is a proven tyre inflation system known for its reliability and value. The system harnesses your existing trailer air supply, ensuring your tyres are fully inflated when your vehicle is in operation. This functionality offers better safety, longer tyre life and optimises on fuel economy to help with your bottom line in the long run.

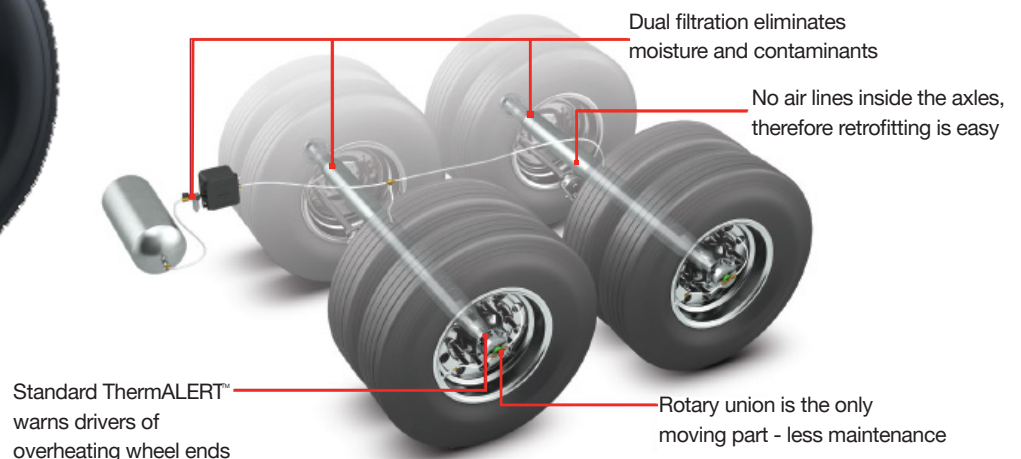

SPECIFICATIONS

MODEL	MTA25T	MTA25L
Suspension Type	Top Mount	Low Mount
Axle Capacity (tonnes)	11.34	11.34
Brake Capacity	12T -ADR Tested	
Axle Track (mm)	1854	1854
Spindle Types	Tapered (TN/TQ) & Parallel (TP)	
Brake Types	Q+ Drum Brakes and EX+ Air disc brakes	
Hanger Type	Weld-On, Bolt-On, Bolt on with side mount	
Hanger Finish	Painted, Galvanized and Stainless Steel	
Ride Heights (inches)	14", 15", 16" & 17"	6.5" 7.5", 8", 9" 12", 14", 15", 17" & 19"
Wheel Ends	Drum: STEELite X30, Cast Iron Hubs: Cast Iron, ADI, Aluminium, Preset+	
Lift Kits	Lift Kit with retrofit capability	
Warranty	5 Years/1 Million km's on major structural components <small>*Sub components warranty varies per component</small>	

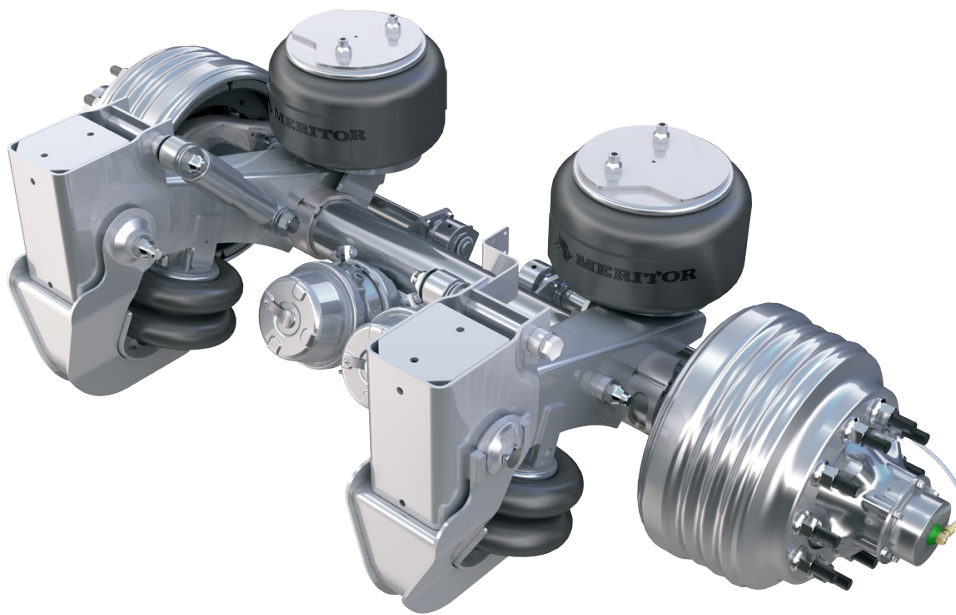

GLOBAL PRESENCE, LOCAL SUPPORT

Our experienced Customer Service and Technical Support teams are based in Australia and will assist with any enquiries. For more information, call (+61 3) 9311 6555.



Meritor Heavy Vehicle Systems Australia
70 Berkshire Road
Sunshine, VIC 3020
AUSTRALIA

(03) 9311 6555

meritorpartsonline.com

CMCVSFL015 - MTA TRAILER SUSPENSION SYSTEMS
04/23

Produced in AUS 04/23
©2023 Cummins Inc.